

FIG. 1A

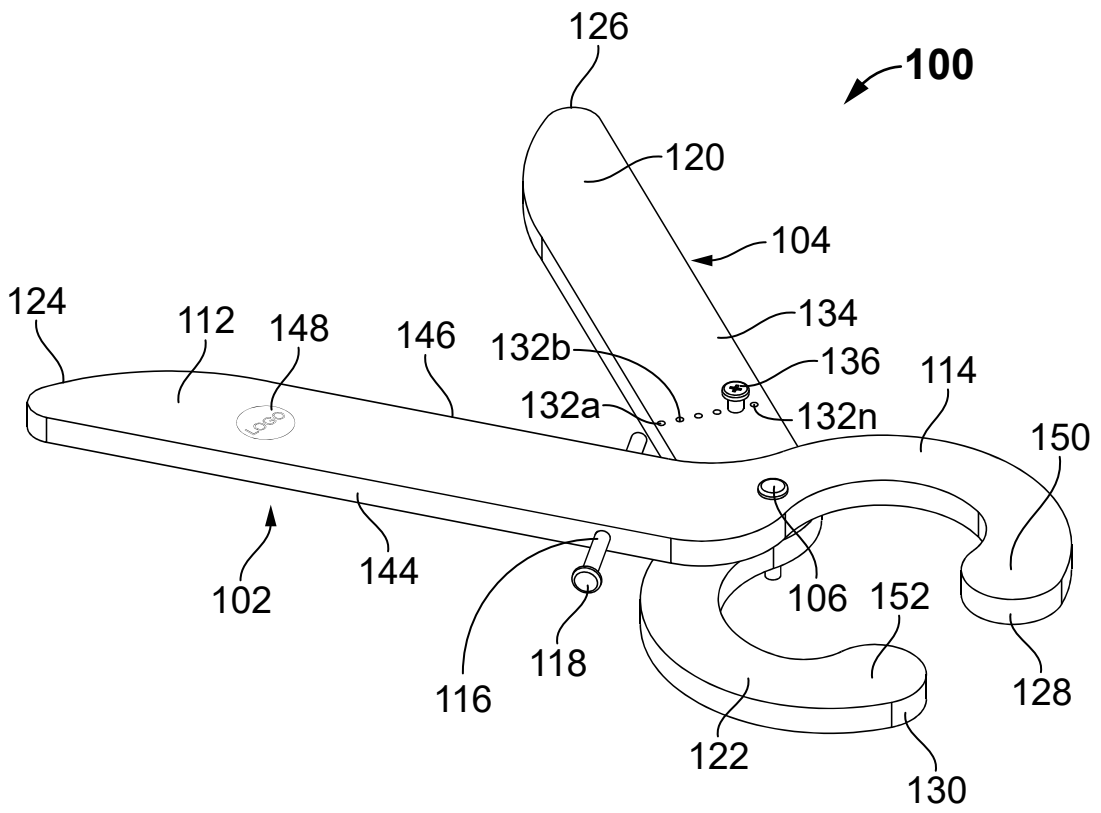

FIG. 1B

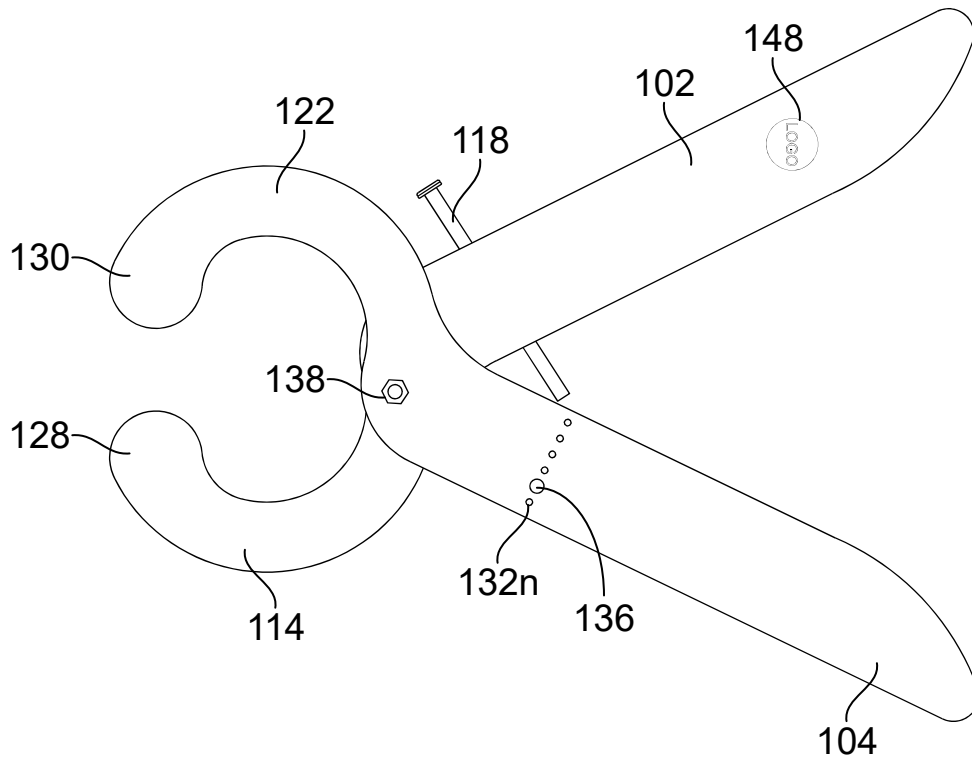

FIG. 2

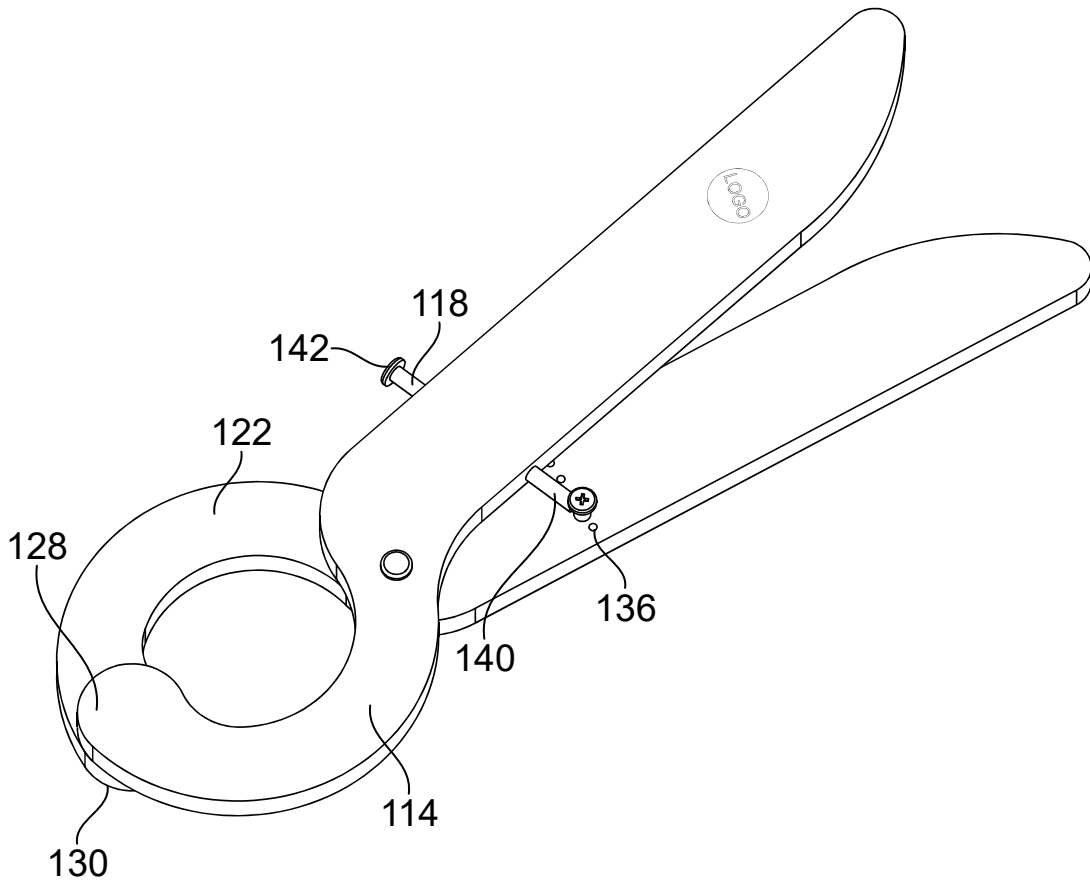

FIG. 3

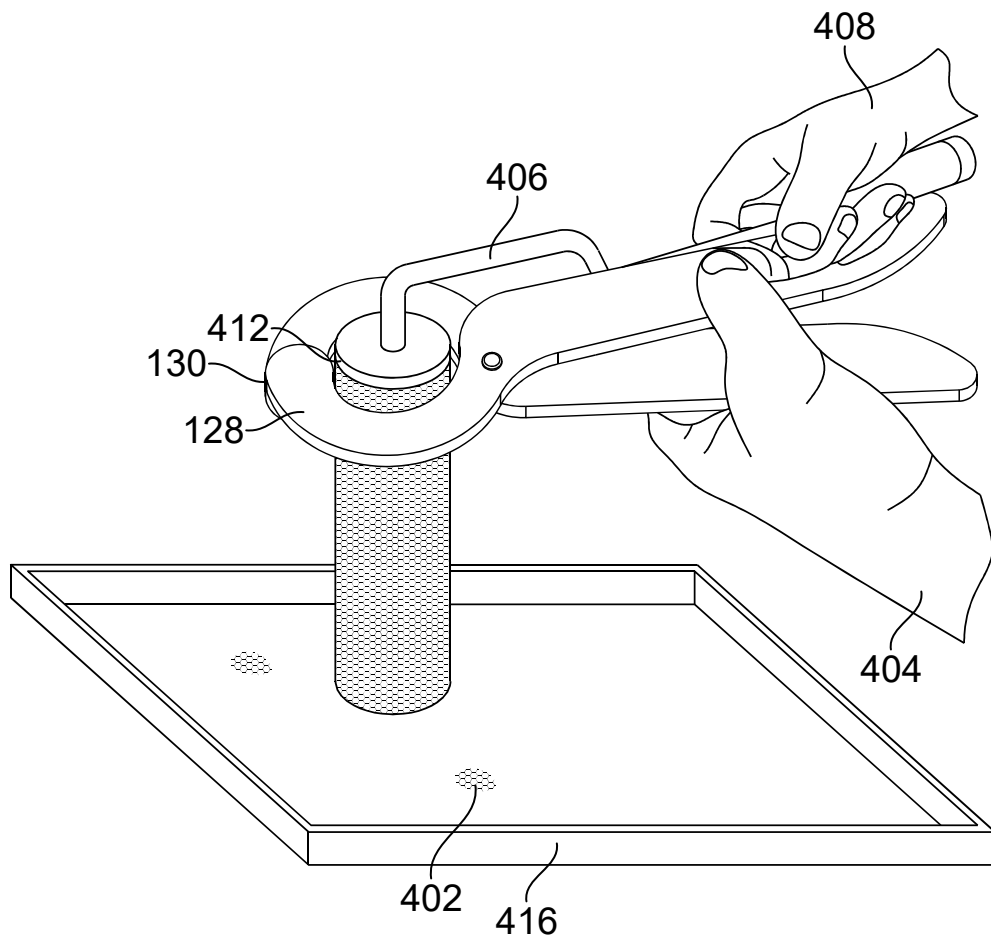

FIG. 4A

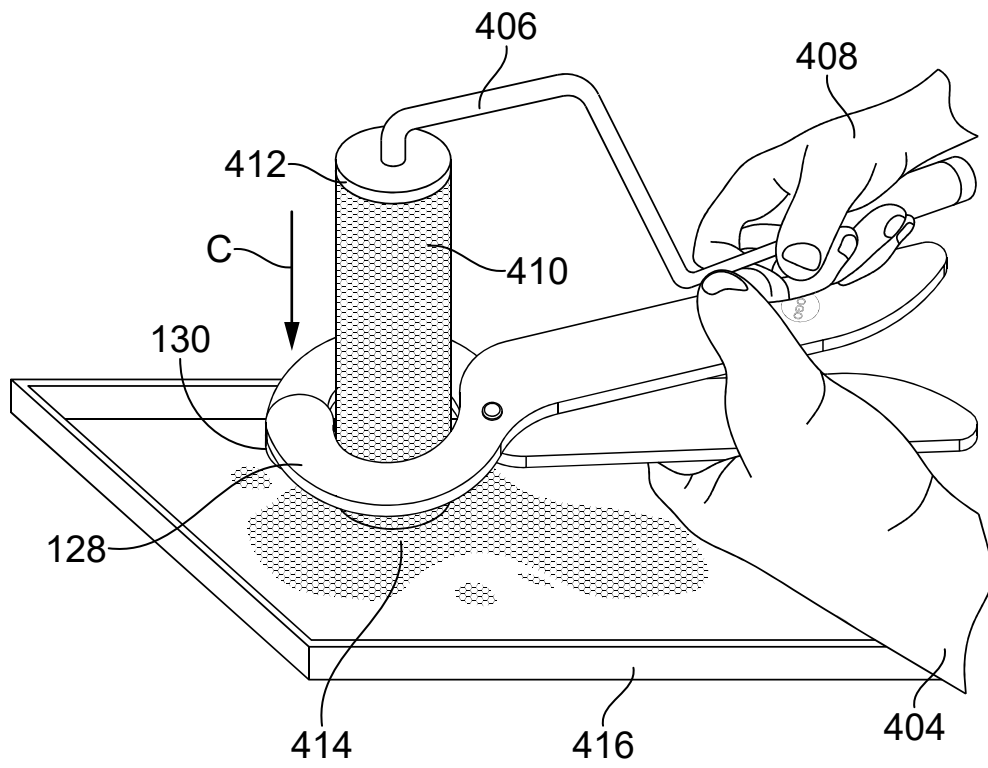

FIG. 4B

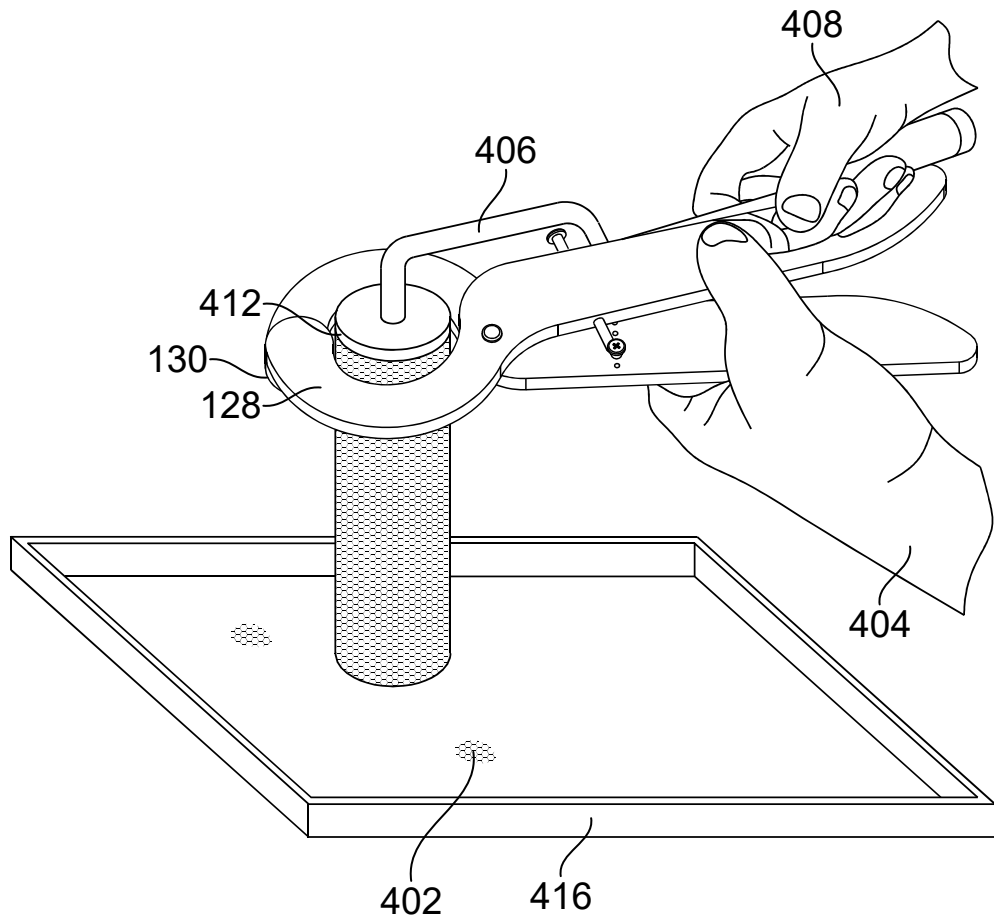

FIG. 5A

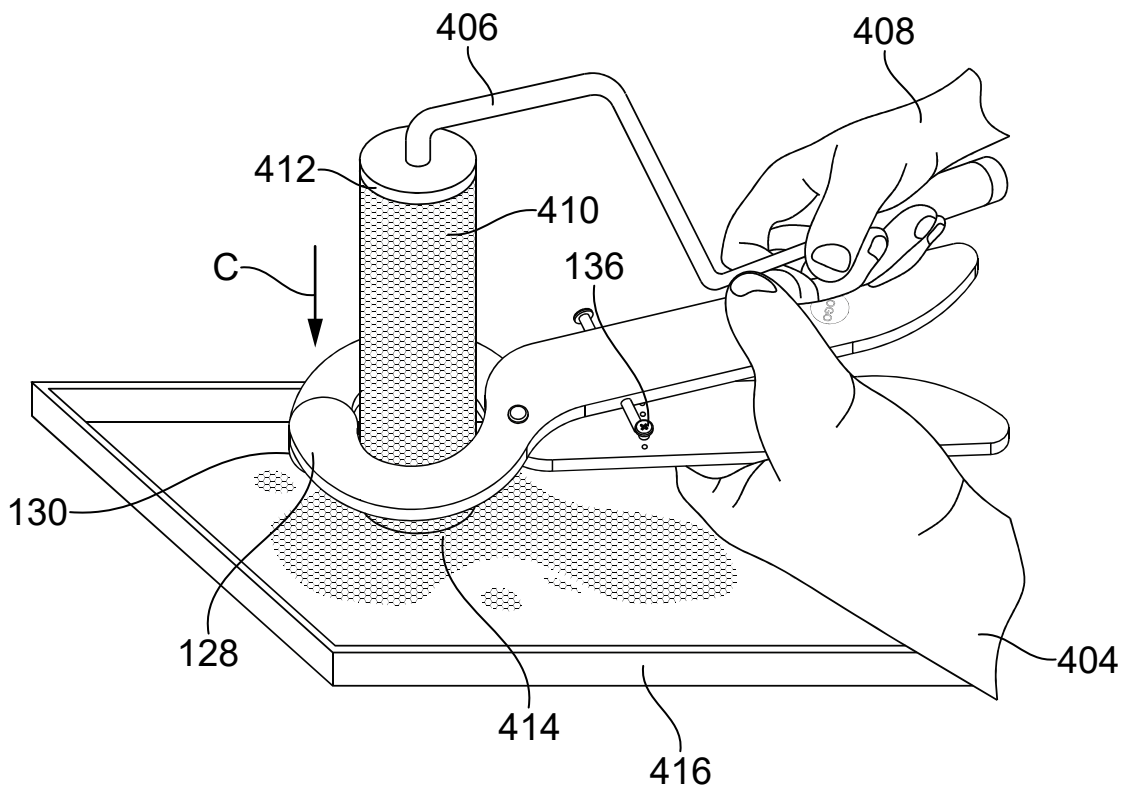

FIG. 5B



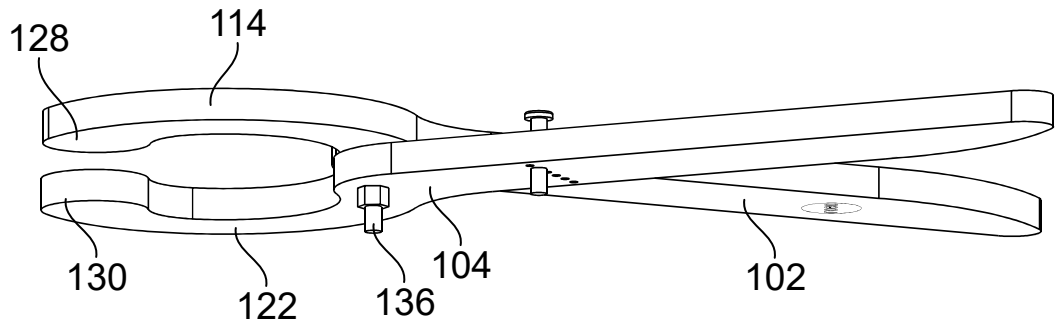

FIG. 6

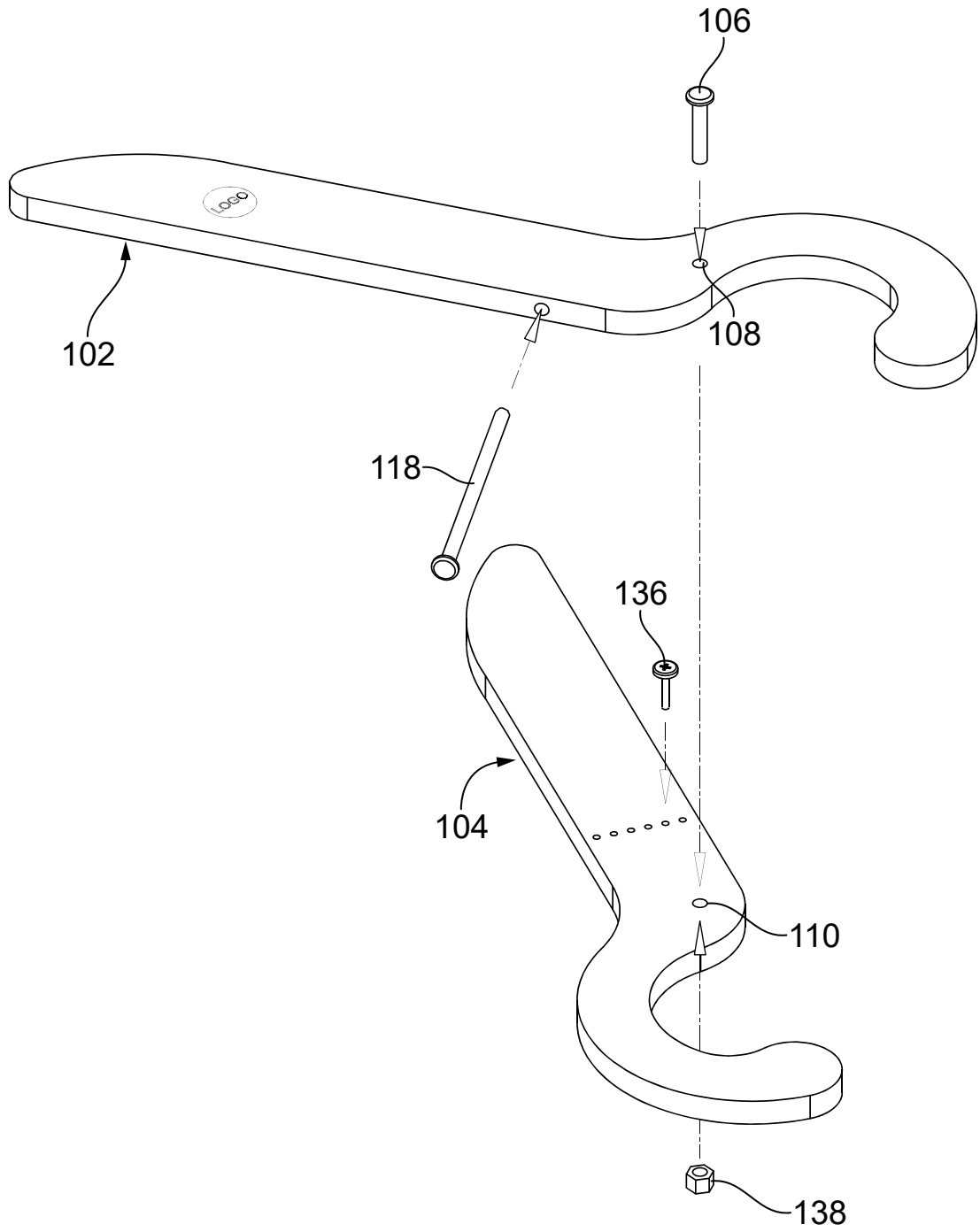

FIG. 7

11/24

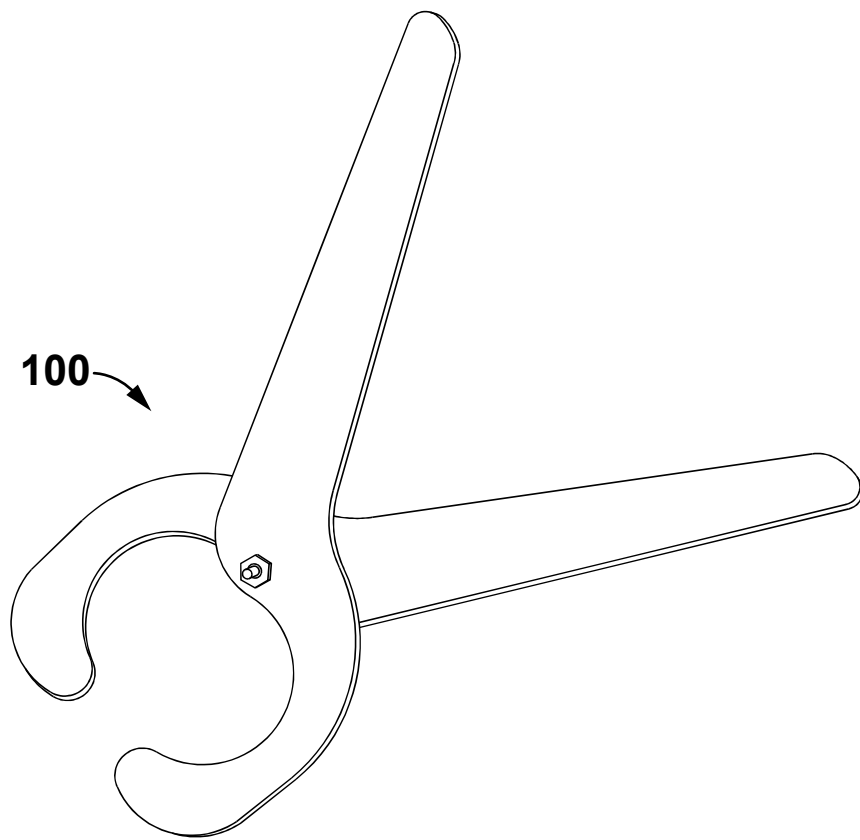

FIG. 8

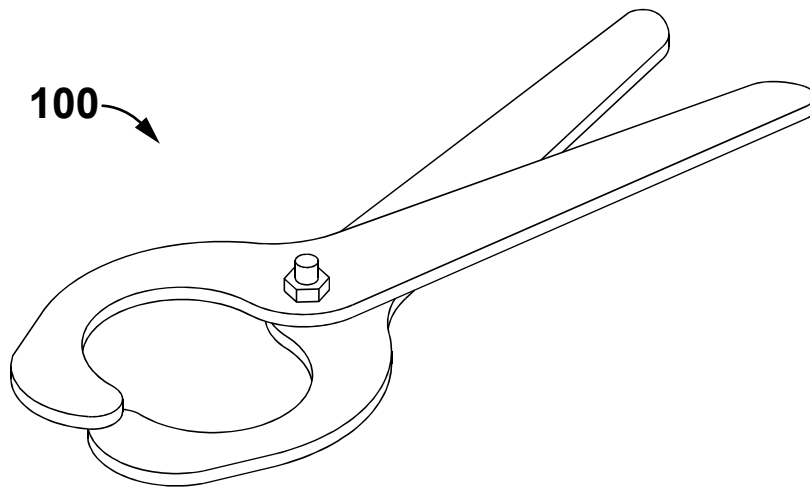

FIG. 9A

100

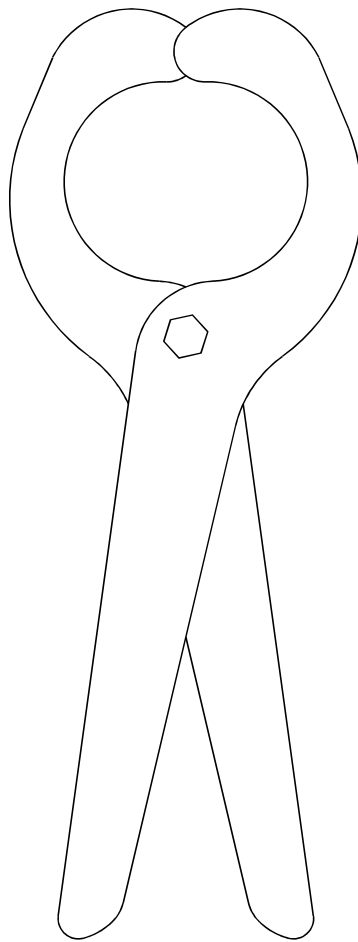

FIG. 9B

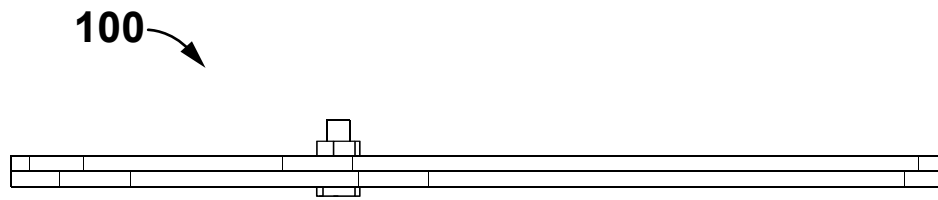

FIG. 9C

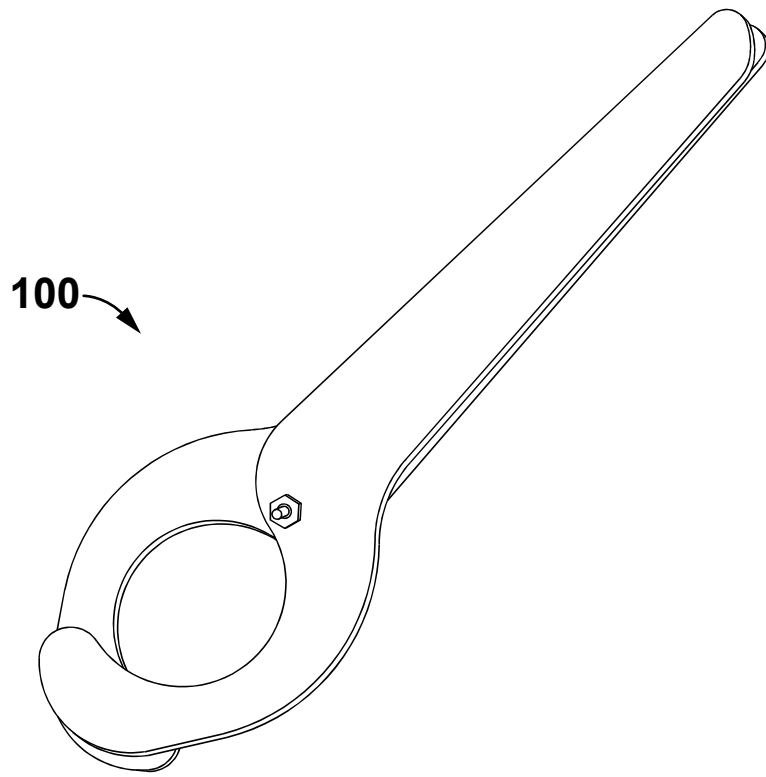

FIG. 10

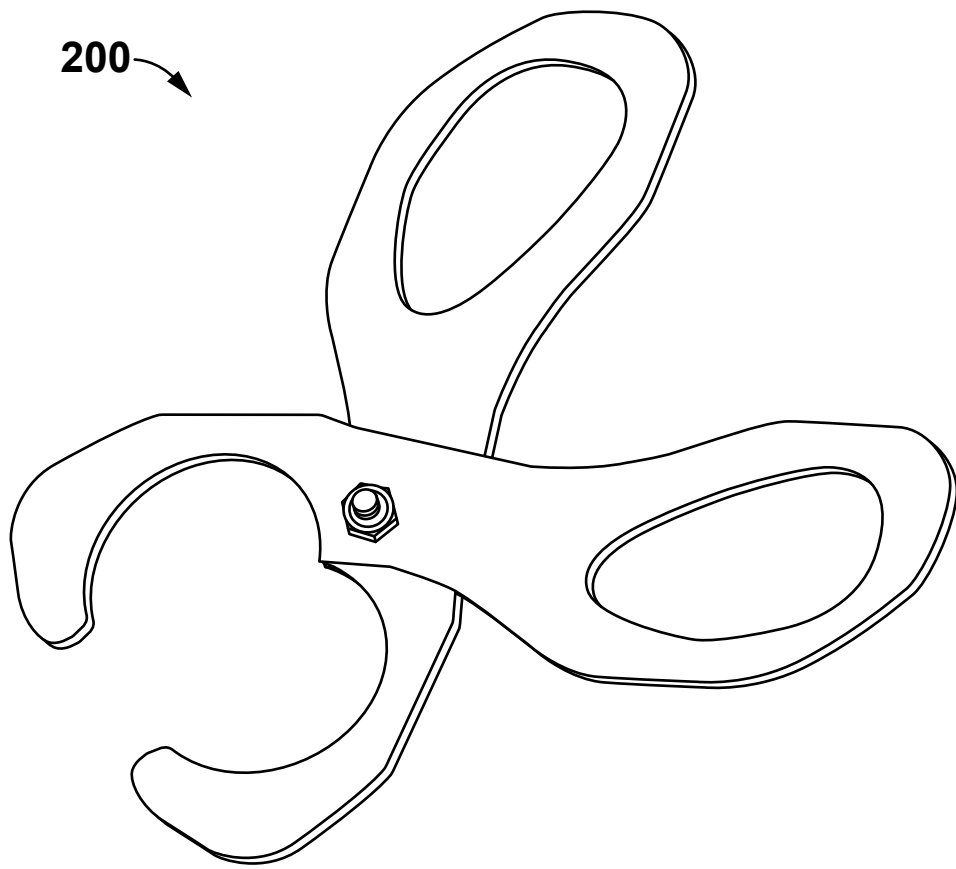

FIG. 11



17/24

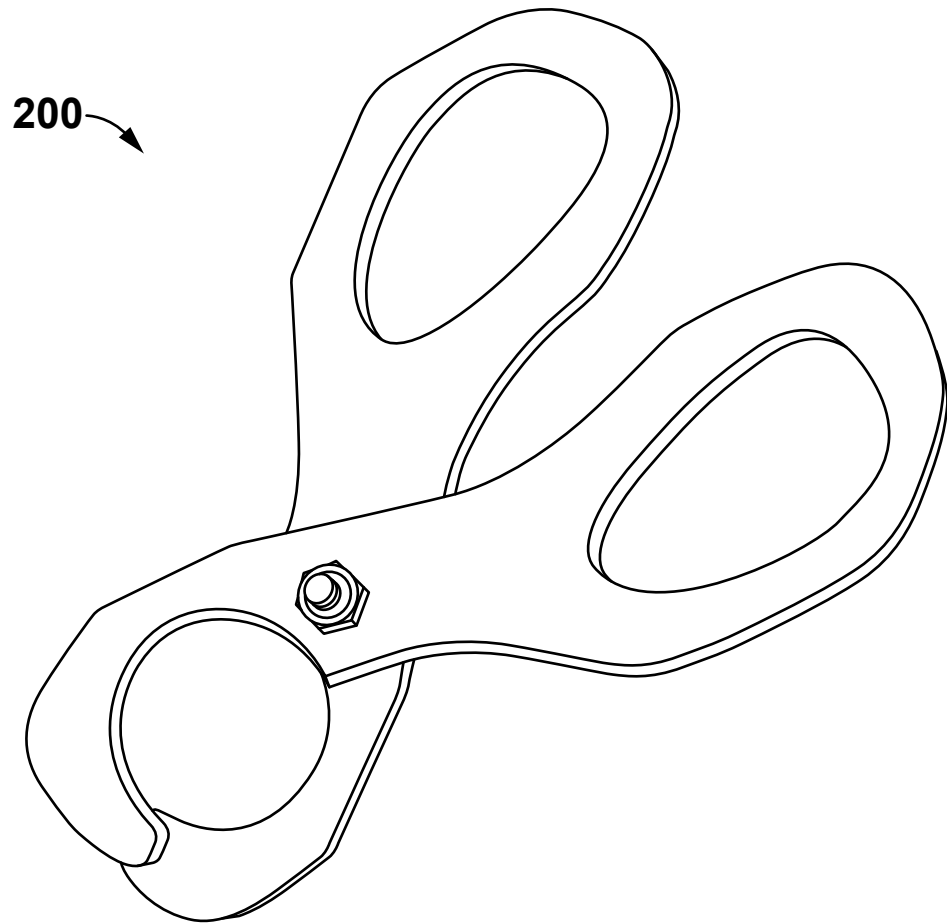

FIG. 12A

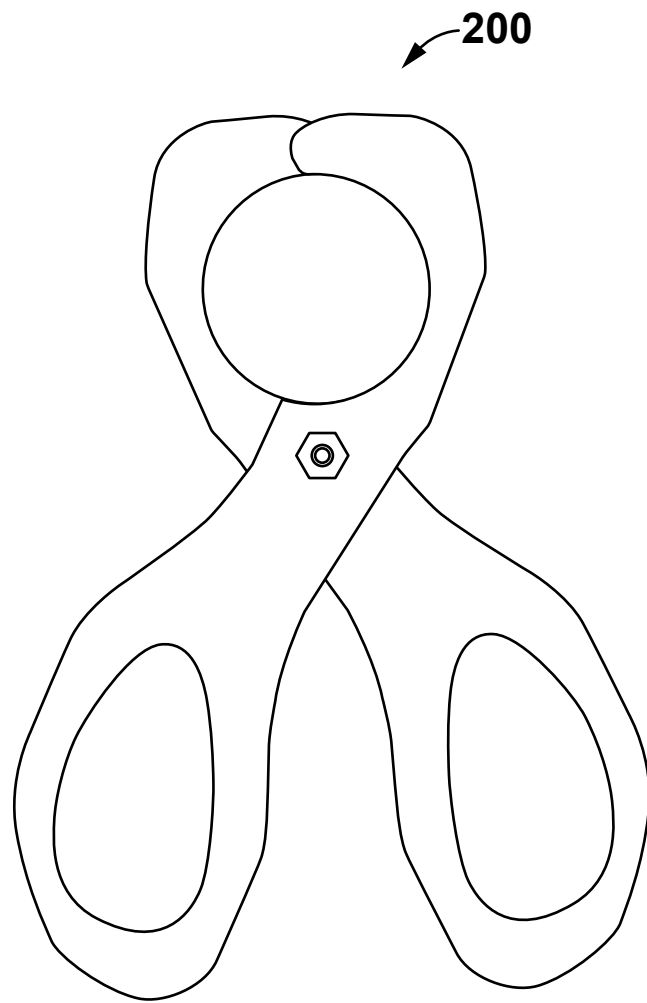

FIG. 12B

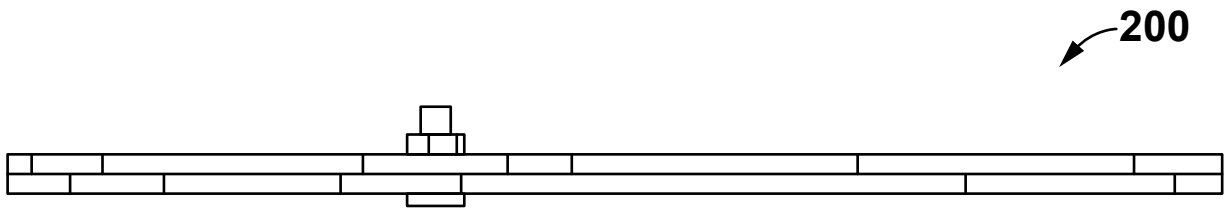

FIG. 12C

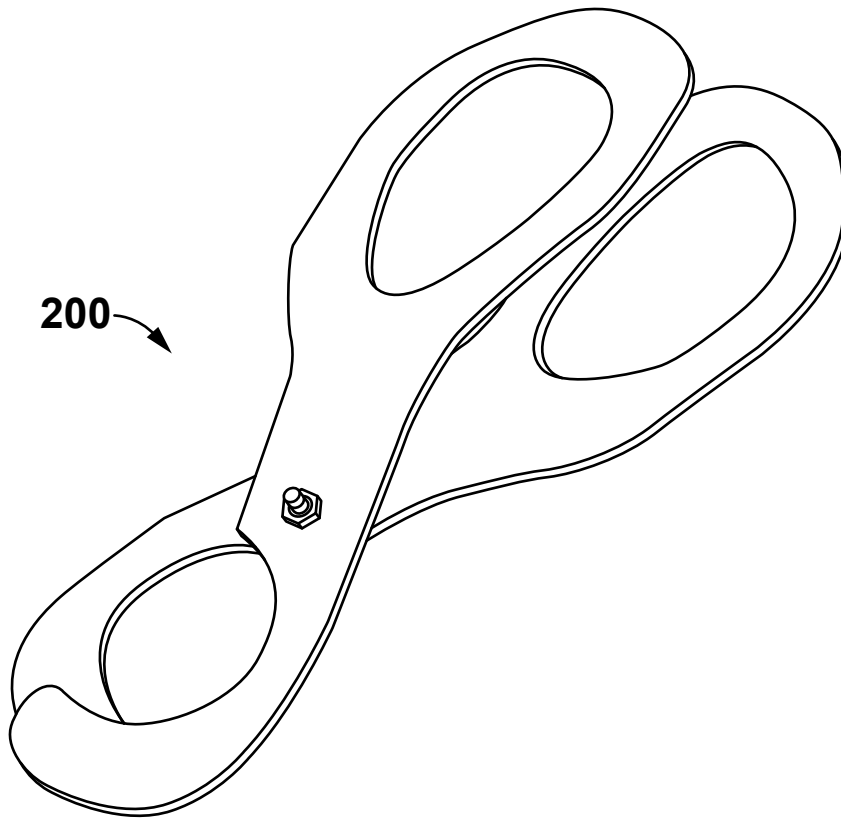

FIG. 13

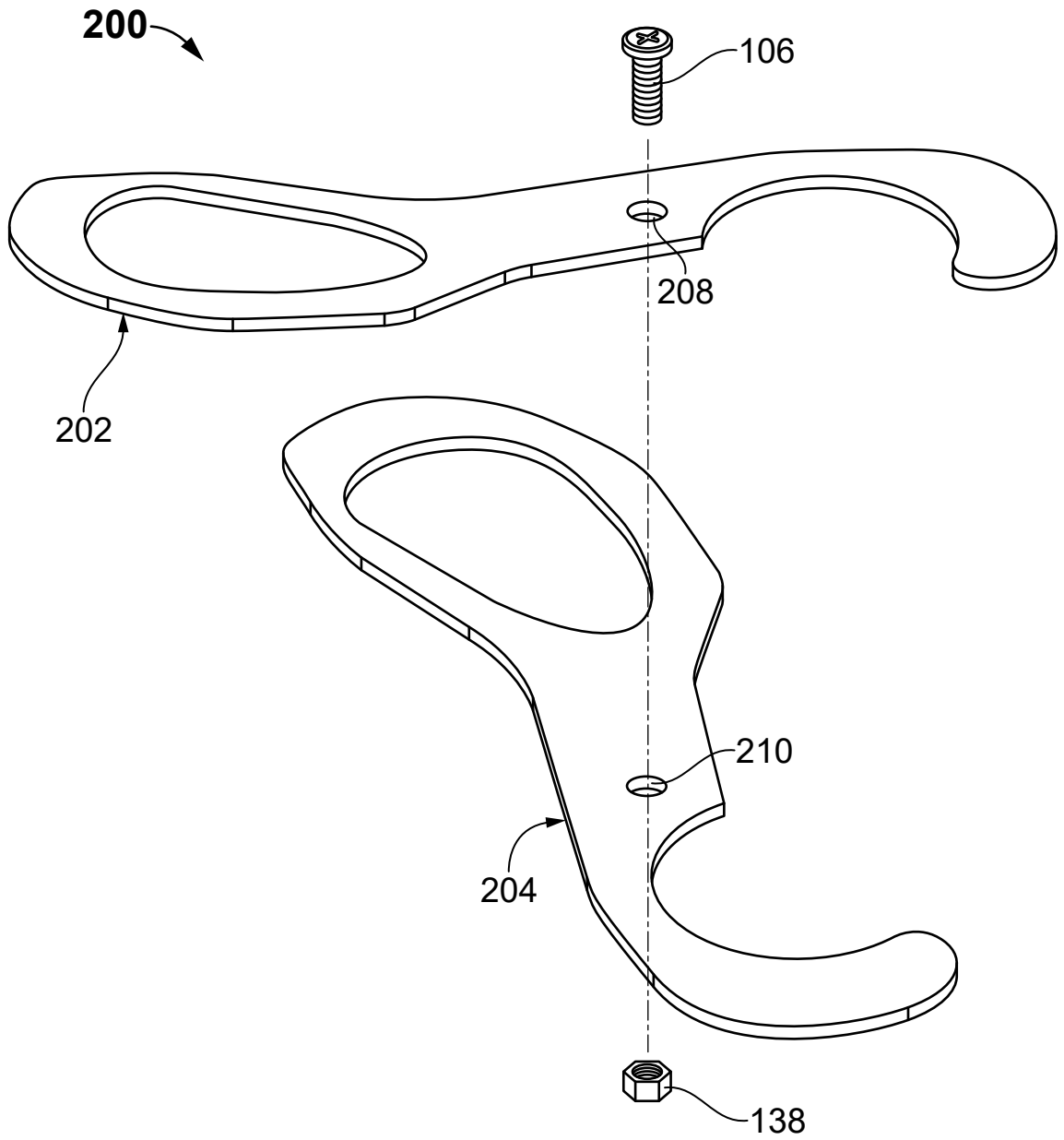

FIG. 14A

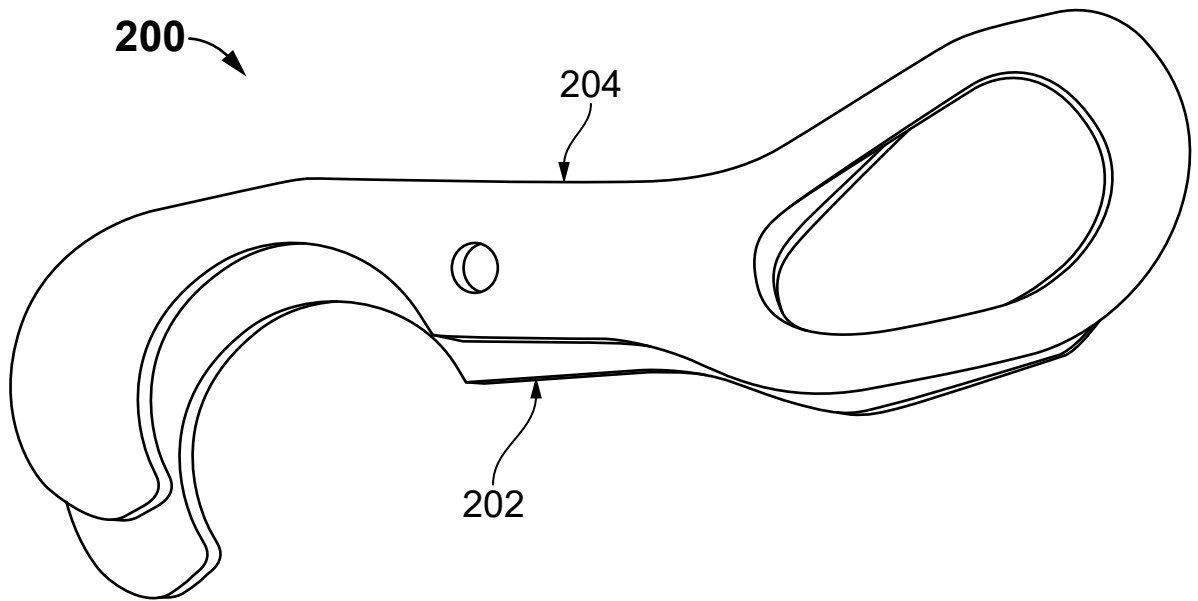

FIG. 14B

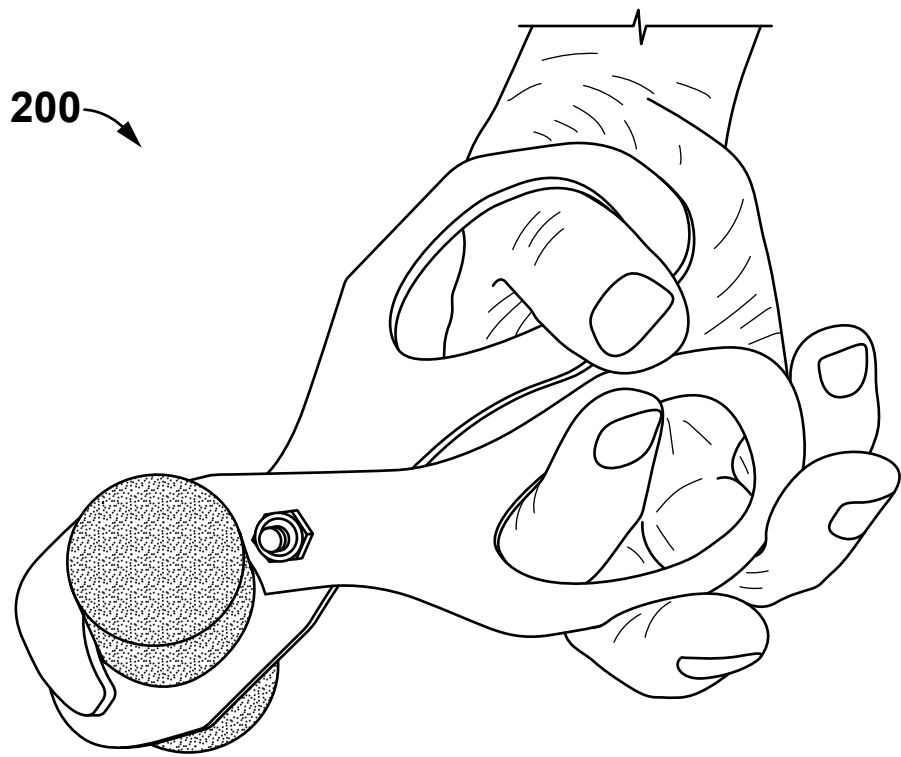

FIG. 15

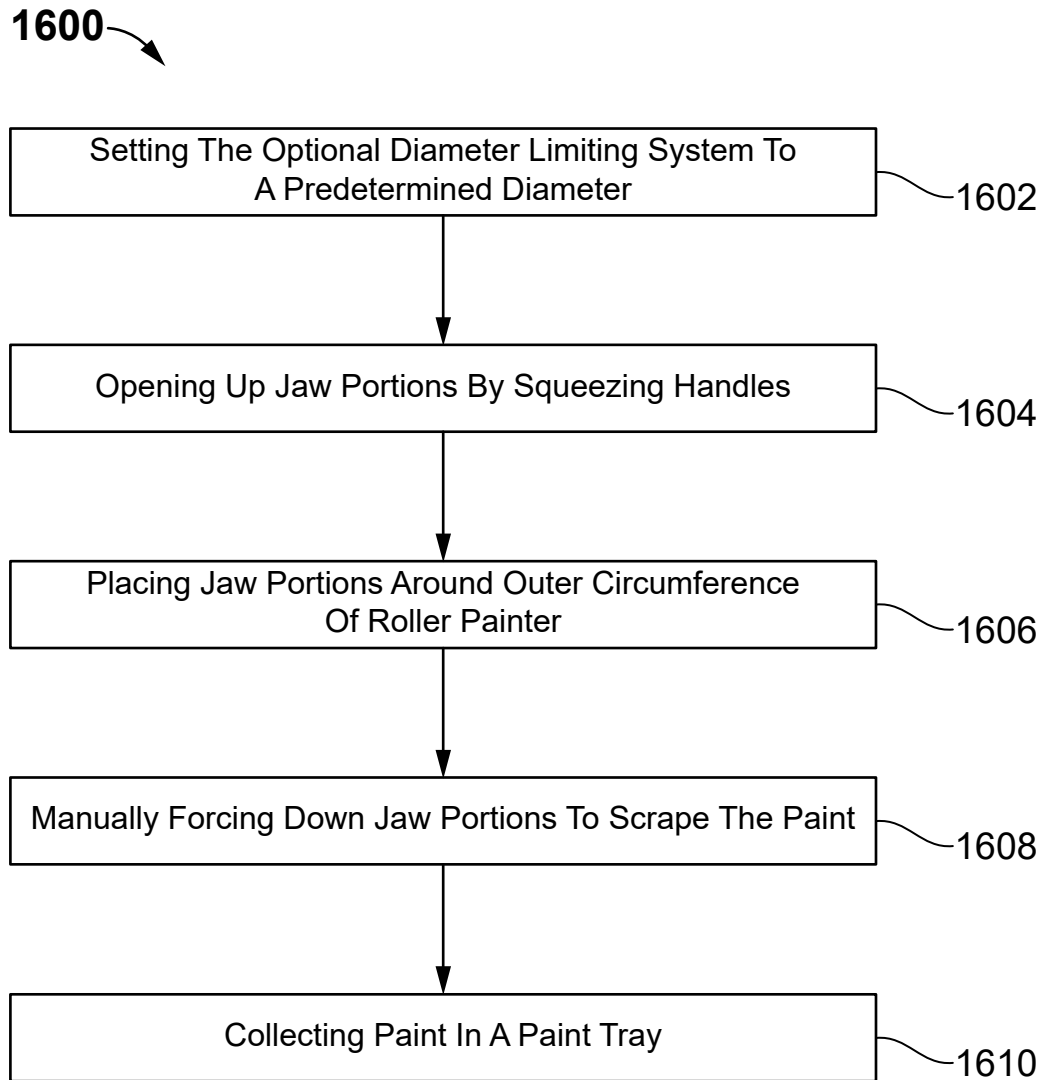

FIG. 16